





-  Loctite "271" Adhesive Sealant (92-809819)
-  Loctite "405" (Purchase Locally)
-  Super Duty Gear Lubricant (92-13783A24)
-  Loctite Primer "N" (92-59327-1)
-  2-4-C w/Teflon (92-825407A12)



3.44 IN./135MM
TORPEDO DIA.

Parts List

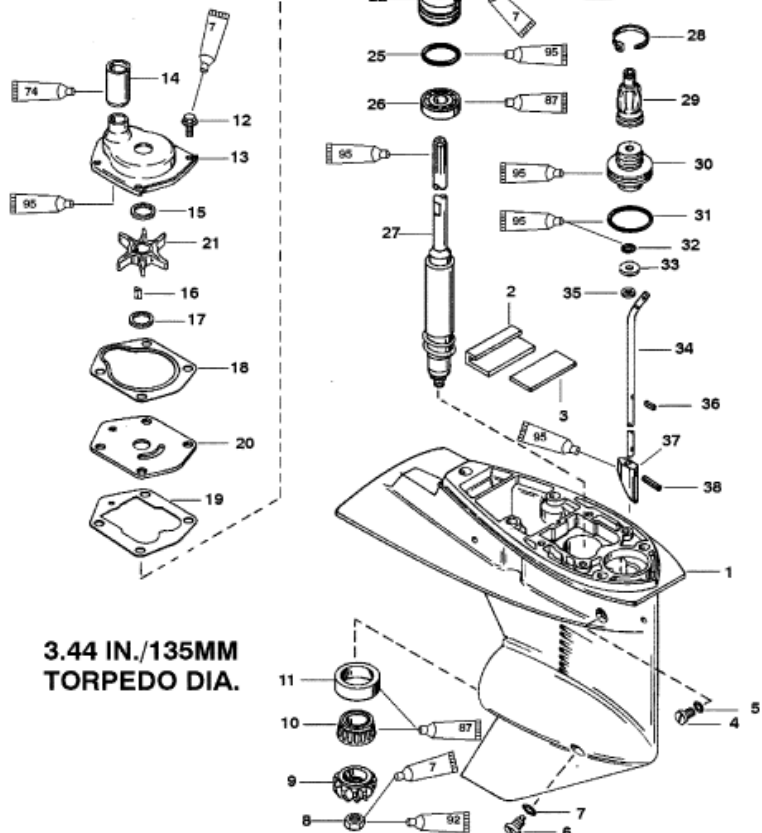
Ref	Class	Part	Description	Qty	Comment	Footnote
-	1682	821306A30	GEAR HOUSING	1	(BLACK) SHORT	
-	1682	821306A31	GEAR HOUSING	1	(GRAY) SHORT	
-	1682	821306A32	GEAR HOUSING	1	(BLACK) LONG	
-	1682	821306A33	GEAR HOUSING	1	(GRAY) LONG	
1	1682	821306A12	GEAR HOUSING	1	(BLACK) BASIC	
1	1682	821306A13	GEAR HOUSING	1	(GRAY) BASIC	
2		818226A	SEAL/PLATE KIT	1		
3		NSS	PLATE	1	(PART OF REF #2)	6
4	10	79953A	SCREW (.375-16 X .25)	1		
5	12	19183	WASHER-SEALING	1		
6	22	67892A	DRAIN SCREW	1	(MAGNETIC)	
7	12	19183	WASHER-SEALING	1		
8	11	828490	NUT	1		
9		NSS	PINION GEAR (PART OF 43-833	1		6
10	31	821321A	BEARING ASSEMBLY-ROLLER	1		
11		NSS	CUP (PART OF REF #10)	1		6
12	10	824832	SCREW (M6 X 16)	4		
13	46	821351A	WATER PUMP UPPER HOUSIN	1		
14		43023	SEAL-WATER TUBE	1	(SHORT - 1-3/4)	
14		823547	SEAL-WATER TUBE	1	(LONG - 2-1/4)	8,9
15	12	86645	WASHER	1		8,9
16	28	85119	KEY	1		9
17	12	86645	WASHER	1		8,9
18	27	822189	GASKET	1		8,9
19	27	822217	GASKET (LOWER)	1		8,9
20		821354	FACE PLATE	1		9
21	47	85089	IMPELLER	1		9
22	46	821307A	WATER PUMP BASE ASSEMBL	1		
23	26	821309	SEAL-OIL	1		8
24	26	821310	SEAL-OIL	1		8
25	25	821308	O RING	1		8
26	30	821311	BALL BEARING	1		
27	45	850177A	DRIVESHAFT	1	(SHORT)	
27	45	832987A	DRIVESHAFT	1	(LONG)	
28		823548	CABLE TIE	1		8
29		822158	BOOT-SHIFT SHAFT	1		8
30		821827	RETAINER-SHIFT SHAFT	1		
31	25	26855	O RING	1		8
32	25	85594	O RING	1		8
33	12	814803	WASHER	1		
34		827865A	SHIFT SHAFT	1	(SHORT)	